



## Movidor HS35

For Ambient / Coolroom Temperature Conditions



The Movidor range of high speed doors by Carona Group have been proven to improve productivity, safety and energy efficiency in high traffic doorways. Designed to maximise the thermal and separation benefits of a closed door, with uninhibited access to a wide range of traffic types, Movidor high speed doors are used extensively in temperature and hygiene control applications, in many industry sectors. With industry leading speed and reliability, Movidor high speed doors provide clear advantages over conventional rapid type doors in a number of key performance indicators

### KEY FEATURES

- Self Repairing Feature
- European Quality Motors and Controls
- Australian Made
- Simple Design
- HACCP Approved

## Movidor HS35

Key: ✓ - Standard ○ - Optional

<b>Max. Size</b>	Daylight Opening Height -mm		4000
	Daylight Opening Width -mm		4000
<b>Door Construction</b>	Curtain	PVC coated polyester, 900gsm	✓
	Windows	1 level of approx. 600H x 850W windows. 1.5mm clear PVC.	✓
		Additional levels of windows.	○
		Mesh windows	○
	Side frames	Anodised aluminium guides and side covers, HDPE guide liners.	✓
	Head Unit	Anodised aluminium front fascia.	✓
	Motor Cover	Anodised aluminium. Gearbox enclosed, lower section of motor exposed	✓
	Full SS Head Unit and Tracks (Optional)	Stainless steel fully enclosed shroud	○
<b>Crash-out Curtain</b>	Automatic, self relocation after crash-out		✓
<b>Curtain Tension</b>	Interior Application, lateral tension	Flexible wind battens enclosed in curtain.	✓
	Exterior Application, lateral tension	Metal wind battens enclosed in curtain	○
<b>Curtain Edge</b>	Flexible, non pressure,	Deformable buffer encased in bottom edge of curtain. Safety Yellow.	✓
<b>Perimeter Seals</b>	Guides	19mm brush each side of guides	✓
	Head Unit	50mm brush to front and back of curtain, in head unit	✓
<b>Safety</b>	Photo electric sensor	Across doorway, enclosed in door columns	✓
	Infrared curtain sensor	Perimeter of doorway, adjustable depth, penetration	○
	Brake switch failure monitor	True/False relays with timer switch to shut brake	✓
	Multi-coloured LED Warning lights	LED lights fitted to guide tracks to indicate curtain position.	○
<b>Motor &amp; Gearbox - SEW</b>	Brake motor & worm gearbox	Direct drive to curtain drum shaft	✓
<b>Control System</b>	Control Cabinet - Powder Coated Metal	400x400x200	✓
	Control cabinet - stainless steel	400x400x200	○
	Variable speed, soft start/stop	Frequency Inverter - SEW	✓
	Supply Voltage	240V, 50Hz, 10A	✓
		415V, 50Hz, 20A	○
	Power Supply	GPO with standard 3 pin plug to control box	✓
		Hard wired to isolator	○
	Control Voltage	24vdc	✓
	Protection	Circuit breaker	✓
	Positioning System	Encoder with positioning sensor	✓
	Operator Controls	Open buttons, Emergency Stop, Status Indicator	✓
		Visible diagnostics	✓
<b>Operation</b>	Opening Speed, approx	Metres per second	2.0
	Closing Speed	Metres per second	0.5
	Automatic	Input to open, automatic close via adjustable hold-open	✓
<b>Emergency Operation</b>	Manual	Ratchet crank to base of motor	○
	Automatic	UPS unit, with impulse to open automatically in power failure	○
<b>Activation Methods</b>	OPTIONS	Illuminated Push Buttons	✓
		Radar with IR safety curtain	○
		Inductive Floor Loop	○
		Remote control with handsets	○
		Pull cord switch	○
		Radar, parallel traffic rejection	○
		Swipe card, security access	○

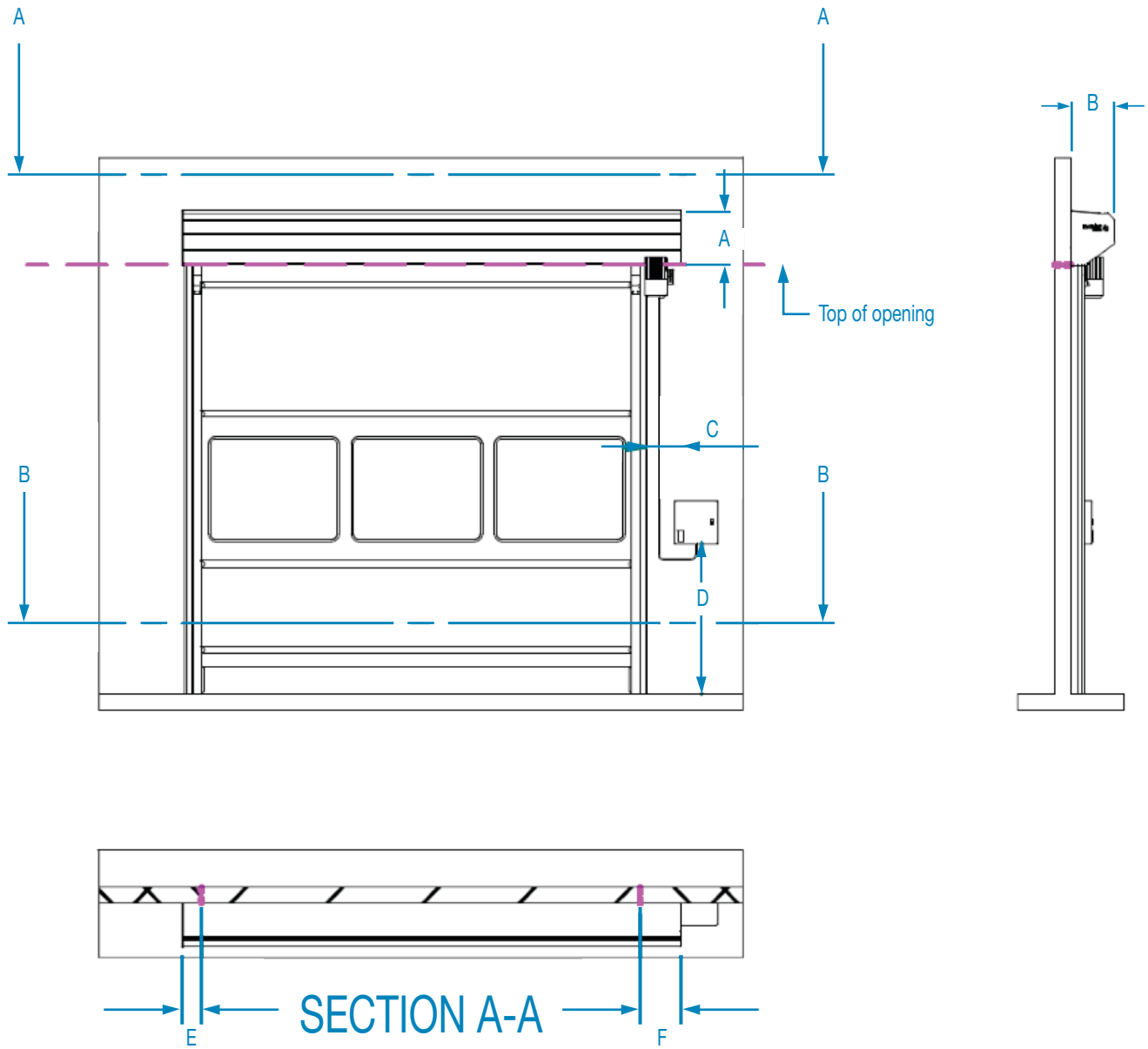

### H35 CLEARANCE DETAILS

MODEL	A	B	C	D	E	F
HS35	495	340	175 FEO	1400 FFL	110	260

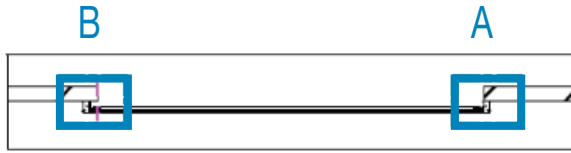

SECTION B-B

Optional concealed track design

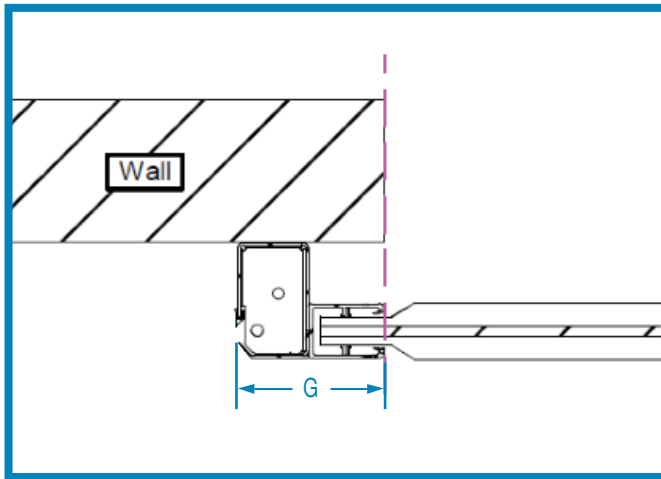

DETAIL B

Standard Design - Tracks proud of opening to allow self relocation feature

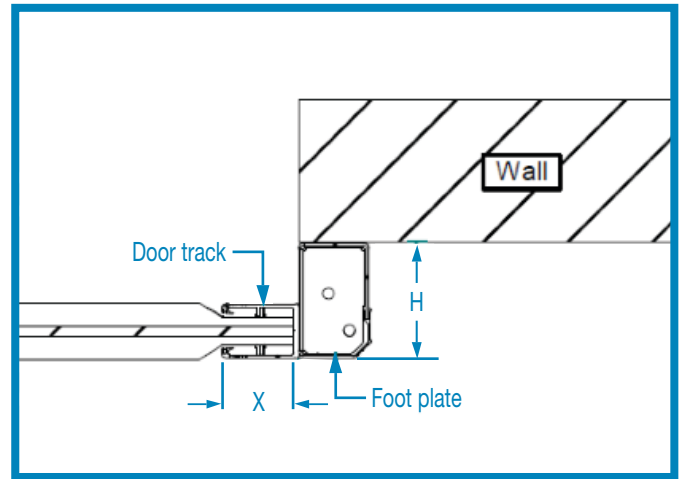

DETAIL A

**H35 CLEARANCE DETAILS**

MODEL	G	H	X
HS35	160	105	85